

THIẾT BỊ ĐIỆN 286

Hotline: 0928.889.286

Website: Thietbidien286.com

EOCR

Electronic Over Current Relay



Whatever your process...

- > Oil & gas, petrochemicals, mining, metals, minerals, water and wastewater treatment, food & beverage, pharmaceuticals, microelectronics, airports...
- > **Our EOCR solutions adapt to the specific requirements of your continuous and critical process.**

Contents

- > Chapter 1_Analog EOCR
- > Chapter 2_Digital EOCR







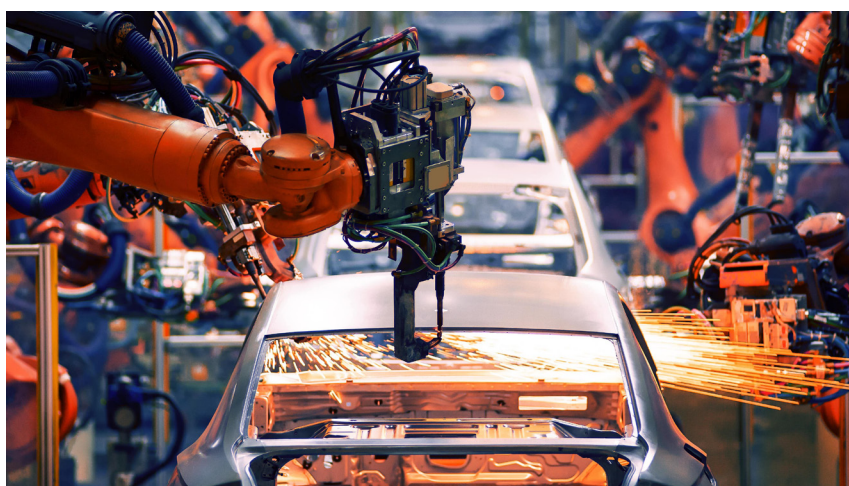

Up to 70%

Source: Motor Decisions MatterSM
in USA - www.motorsmatter.org

The share of total electrical energy consumed
by motors within the infrastructure and
industrial sectors.



EOCR Selection Guide

		Digital EOCR						Analog EOCR		
										
Product Name		iFBZ/ i3BZ	iFMZ/ i3MZ	iFM420/ i3M420	iFDM/ i3DM	FBZ2/ 3BZ2	FMZ2/ 3MZ2	FDM2/ 3DM2	EOCR- SSD	EOCR- SS
Control Supply	100~240V AC/DC	100~240V AC/DC	100~240V AC/DC	100~240V AC/DC	100~240V AC/DC	100~240V AC/DC	100~240V AC/DC	100~240V AC/DC	24~240V AC/DC	24~240V AC/DC
	24V AC/DC	24V AC/DC	24V AC/DC	24V AC/DC	24V AC/DC	24V AC/DC	24V AC/DC	24V AC/DC	-	-
	50/60 Hz	50/60 Hz	50/60 Hz	50/60 Hz	50/60 Hz	50/60 Hz	50/60 Hz	50/60 Hz	50/60 Hz	50/60 Hz
Single Phase Application		•	•	•	•	•	•	•	•	•
Three Phase Application		•	•	•	•	•	•	•	•	•
Current Sensing		3CT	3CT	3CT	3CT	3CT	3CT	3CT	2CT	2CT
Connection	Window hole	•	•	•	•	•	•	•	•	•
	Bottom hole	•	•	•	•	•	•	•	-	-
Protection Function	Overcurrent	•	•	•	•	•	•	•	•	•
	Under Current	•	•	•	•	•	•	•	-	-
	Locked rotor when motor starts	•	•	•	•	•	•	•	•	*
	Locked rotor when motor runs	•	•	•	•	•	•	•	-	-
	Current phase loss	•	•	•	•	•	•	•	•	*
	Current reverse phase	•	•	•	•	•	•	•	-	-
	Unbalancing current	•	•	•	•	•	•	•	-	-
	Thermal inverse	•	•	•	•	•	•	•	-	-
	Earth leakage	•	•	-	-	•	•	-	-	-
Indicator Function	Average current	•	•	•	•	•	•	•	-	-
	Ground current	•	•	•	-	•	•	-	-	-
	Total motor run hour	•	•	•	•	•	•	•	-	-
	Trip indicator	•	•	•	•	•	•	•	•	-
	Trip history	•	•	•	•	•	•	•	-	-
	Load ratio (Bar-graph)	•	•	•	•	•	•	•	-	-
	Display type	5 digit 7-segment	5 digit 7-segment	5 digit 7-segment	5 digit 7-segment	5 digit 7-segment	5 digit 7-segment	5 digit 7-segment	4 digit 7-segment	LED indication
Auxiliary Function	Alert output	-	-	-	•	-	-	•	-	-
	Password setting	•	•	•	•	•	•	•	-	-
	Fail safe On/Off	•	•	•	•	•	•	•	•	•
	Low Frequency Operation	•	•	•	•	•	•	•	-	-
	Limitation of autoreset attempt	•	•	•	•	•	•	•	-	-
	Operation timer setting	•	•	•	•	•	•	•	-	-
	Restart Limitations	•	•	•	•	•	•	•	-	-
	Built-in ZCT	•	-	-	-	•	-	-	-	-
Communication Function	4~20mA Loop current	-	-	•	-	-	-	-	-	-
	Function	•	•	•	•	-	-	-	-	-

* Trip by Over Current

Analog EOCR

EOCR-SS

Static & electronic over current relay developed to resolve the drawbacks of previous thermal/induction relays



- Micro compact size
- Protection against over current/phase loss/locked rotor (phase loss/locked rotor operates by over current)
- Separate setting for startup delay/operation delay time
- Relay resistant to vibration and short-circuit applied (1a1b applied) * 1c for standard type
- Integrated AC/DC operating power supply (Free voltage) * AC 100-240V for standard type
- Operation display and active current check (LED)
- Manual (instant)/electrical reset
- Capable of protecting the motor with precisely applied MCU
- NVR (No Volt Release) function / Fail Safe
- Super power-saver and strong environmental resistance

Usage

- Under voltage induction motor (600V)/High voltage motor(3.3kV) protective relay (uses high voltage CT)
- Shock relay by specialized machine
- Current relay for fault monitoring
- For replacement of thermal protective relay

Protection Function

Protected Items	Operation Time
Over Current	O-TIME
Phase Loss	O-TIME
Locked Rotor	O-TIME + D-TIME

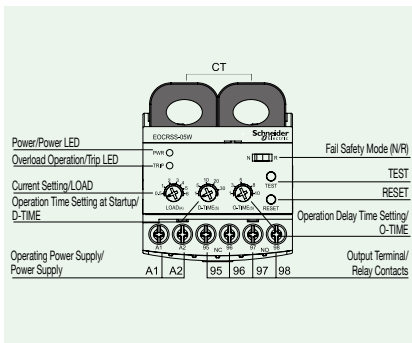

LED

Current System Functions Detailed Setting	With current setting, the LED flickers when the current indicator of the setting knob is at 100% of the active load current. This means that it is possible to proceed with the setting after checking the active current, and a setting of up to 103% is possible.
Operation/Operation Display	Relay Operation: Red Power Supplied/Normal operation: Green

Manual (Instant) Reset/Electrical Reset

Press the RESET button or cut the power (L1, L2) - install SW. in remote locations, remote reset function available

Setting

Set as follows after completing the installation.

Category	Setting Knob	Method
Start Delay Time	D-TIME	Turn the D-TIME Knob to set it based on the startup time of the motor
Operation Time	O-TIME	Turn the O-TIME Knob to set at the desired operation time
Current	LOAD	1. After starting the motor, gradually turn the LOAD Knob counterclockwise from the max. value to find the spot at which the LED begins to flicker (active current point) 2. To set to 103%, turn the Knob clockwise to find a spot where the LED is turned off - If this method seems inconvenient, simply set it to 110%~125% of the active current value (item 1).

TEST Method

- After all wiring tasks are complete, if control power is supplied and the Test button is pressed and held, the red LED will illuminate. If the output contact operates when the set D-TIME and O-TIME elapse, it is working properly, and its operating status is normal.
- Press the Reset button or cut the control power to immediately reset.
- If the control power functions properly, but the green LED does not, repair service is required.
- Test function is available only after the motor has stopped.

Operation Display

Condition		PWD LED		TRIP LED
Power Supply	Flicker		Lights-out	
In Operation	Flicker		Flicker	
Normal operation	Lights-on		Lights-out	
In Overload	Lights-on		Lights-on	
Upon operation/trip	Lights-out		Lights-on	

Hotline: 0928.889.286 / Website: Thietbidien286.com

Analog EOCR

EOCR-SS

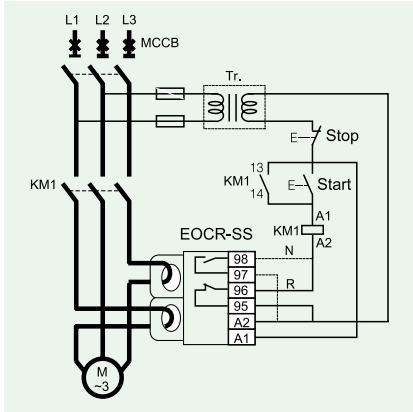

* "N" (Fail safe) Type converts 95 → 96 to open and 95 → 98 to close when operating power is supplied to A1 and A2 (or L1 and L2).

Specifications

Current Setting		Type	Setting Range
		5	0.5 ~ 6A
		30	3.0 ~ 30A
		60	5.0 ~ 60A
		60 ~ 400	Used in combination of 05Type and an external CT (external CT current transformer ratio: 100/5A~400/5A)
Time Setting	Start Delay Time	D-TIME	0.5 ~ 30 sec
	Operation Time	O-TIME	0.5 ~ 10 sec
Reset			Manual (Instant)/Electrical (Remote) Reset
Operation Time Characteristic			Definite
Error Tolerance		Current	±10%
		Time	±15%
Operating Power Supply	Voltage	S (advanced)	24~240V AC/DC
	Frequency		50/60Hz
Auxiliary Contact	Format		Advanced: 2-SPST (1a1b)
	State	R Type	Normally de-energized (regardless of power supply: 95-96 Close, 97-98 Open)
		N Type	Normally energized (after power is supplied: 95-96 Open, 97-98 Close)
	Rated		AC250V/3A resistive load
Insulation	Resistance	Between case and circuit	100 MΩ or higher with a DC500V Megger
		Between contacts	2.0kV power frequency for 1 min
	Withstanding Voltage	Between contacts	1.0kV power frequency for 1 min
		Between circuits	2.0kV power frequency for 1 min
Usage Environment	Temperature	For storage	-30~80 °C
		For operation	-20~60 °C
	Humidity		30~85% RH with no dew condensation
Attachment			35mm DIN Rail/Panel

Dimension

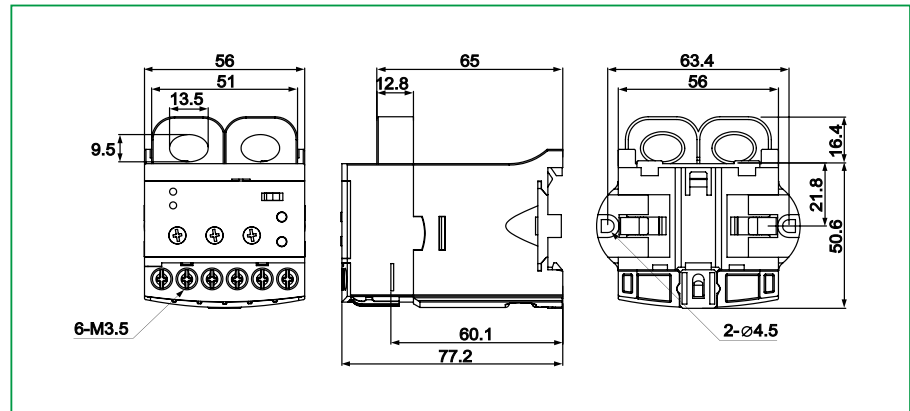

To order an EOCR-SS:

Selection Table

E O C R S S - 0 5 S

① ②

①	Current Rating Range	5	0.5-6A	For 60A or higher, combine 05T Type and an external CT (Secondary 5A) for use
		30	3.0-30A	
		60	5.0-60A	
②	Operating Power Supply	S	24-240V AC/DC	
		W	380-440V AC	

Analog EOCR

EOCR-SSD

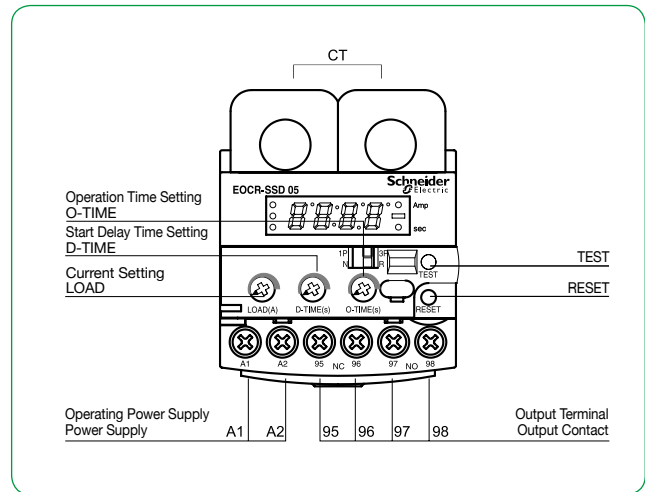

Main Features

- The compact design enables installation in a narrow space (can be replaced with an SS type on 1:1 basis)
- Accurate display of operating current via the frontal LED display (the higher current value will be displayed, whichever is higher between L1 and L3)
- LED window displays the trip cause when a trip occurs
- Accurate phase loss protection (3 sec)
- Easy application: Can select between single-phase (1P) or 3-phase (3P) using DIP SW.
- Works well with an inverter system: 20~200Hz
- Can select contact output[Fail safe(N)/Non-fail safe(R)]: Maximum convenience for sequence configuration
- Easy installation, with DIN Rail and Panel Mounting compatibility

Protection Function

Protection Function	Operation Time
Over Current	Operates after O-Time
Phase Loss	Operates within 3 sec
Locked Rotor	Immediately operates if 200% or more of the set current continues after D-Time

Trip Cause Display and Check Method

Operation Display (Trip Indication)		
Trip Cause	Trip Cause Display	Description
Over Current		Trips after detecting the over current of 10A during operation.
Phase Loss		Trips by L1 (R) phase loss.
		Trips by L2 (S) phase loss.
		Trips by L3 (T) phase loss.
Locked Rotor		Trips when a stall is detected.

Analog EOCR

EOCR-SSD

Specifications

Functions and Characteristics			Specifications
Current Setting	Over Current	5	0.5~6A
		30	3~30A
		60	10~60A
		60A or higher	Use 05Type in combination with an external CT
Time Setting	Start Delay Time	D-Time	1~30 sec
	Operation Time	O-Time:	0.5/1~10 sec
Reset			Manual(instant) reset/electrical reset (power supply cut)
Operation Time Characteristic	Over Current		Definite
Error Tolerance	Current		±5%
	Time		±0.2 sec
Usage Environment	Temperature	Operation	-20°C~60°C
		Storage	-30°C~80°C
	Humidity		30~85% RH without icing
Output contact	2-SPST (1a1b)		AC250V/3A resistive load
Insulation	Resistance	Between circuit and case	10 MΩ at DC500V
		Withstanding Voltage	Between circuit and case
		Between contacts	1.0kV, 60Hz for 1 min
		Between circuits	2.0kV, 60Hz for 1 min
Attachment Method			35mm DIN Rail or Panel
Electrostatic Discharge	IEC61000-4-2	Level 3 :	Air Discharge : ±8kV
			Contact Discharge : ±6kV
Radiated Electromagnetic Field Disturbance	IEC61000-4-3	Level 3 :	10V/m, 150MHz & 450MHz
			Portable Transceiver
EFT/Burst	IEC61000-4-4	Level 3 :	±2kV, 1 Min
Surge	IEC61000-4-5	Level 3 :	1.2×50μs, ±4kV(0°, 90°, 180°, 270°)
Conducted Disturbance	IEC61000-4-6	Level 3 :	10V, 0.15~80MHz
1MHz Burst Disturbance	IEC61000-4-12	Level 3 :	2.5kV, 1MHz
Conducted Emission	EN55011	Level 3 :	Class A (Conducted & Radiated)

Function Setting Sequence and Settings Menu

• Configure the setting as follows before operating the motor:

- Operating Current Setting
 - Set it on the motor's rated current, but in order to protect the machine as well as the load, check the active load current with the digital indicator under normal load state after the startup is complete, and set it to be higher (110%~125%) than the operating current by turning the LOAD knob.
- Start Delay Time
 - ① Set it to max and start the motor.
 - ② After starting the motor, check the current while measuring the time it takes for the operating current to return to normal current. Set the start delay time to about 1 sec longer than the measured time using the D-TIME knob. (For Y- startup, set it to 1~2 sec longer than the full start timer)
- Operating Time: Set the time it takes for the relay to operate from the moment the current flow exceeds the current set value using the O-TIME Knob.













Sequence	Items	Display	Setting Method	Notes
1	Over Current Setting		05 Type : 0.5A~6A 30 Type : 3A~30A 60 Type : 10A~60A	<ul style="list-style-type: none"> • 0.5~6A : Changes in increments of 0.1A • 3~30A : Changes in increments of 1A • 10~60A : Changes in increments of 1A
2	Start Delay Time Setting		1~30 sec	<ul style="list-style-type: none"> • Changes in increments of 1 sec
3	Over Current Operation Time Setting		0.5, 1~10sec	<ul style="list-style-type: none"> • 0.5sec • 1~10 sec (Changes in increments of 1sec)
4	TEST Function		After 3 sec + set O-Time is elapsed, displays END	After 3 sec + set O-Time, TEST is no longer possible during operation.

Analog EOCR

EOCR-SSD

TEST Function

Each set value and the health status of the relay can be checked by pressing the TEST button.

Before the motor starts		After the motor starts
<p>The set value for each setting mode can be checked each time the TEST button is pressed. Test function is completed after going through the TEST mode, which checks the set values and inspects the health status of the EOCR itself.</p>		<p>Each time the TEST button is pressed, the set value for each setting mode can be checked.</p>
 ↓ (RESET) pressed	<p><u>Current Display</u> Displays higher current value between L1 and L2 Before startup: In=0A, after startup: In=3.85A</p>	 ↓ (TEST) pressed
 ↓ (RESET) pressed	<p><u>Current Setting Mode</u> Current Setting (Is)=4.5A</p>	 ↓ (TEST) pressed
 ↓ (RESET) pressed	<p><u>Start Delay Time (D-TIME) Setting Mode</u> D-TIME=10 sec</p>	 ↓ (TEST) pressed
 ↓ (RESET) pressed	<p><u>Operation Time (O-TIME) Setting Mode</u> O-TIME=5 sec</p>	 * (TEST) pressed
 ↓ (TEST) 3 sec + set O-Time elapsed	<p>Self-TEST begins</p>	<p>Does not perform in Relay Test mode in order to prevent a trip accident during operation.</p>
 ↓ (RESET) pressed	<p>Self-TEST in progress Self-TEST completed After setting O-TIME, the contact of inner Relay is passed and the self-TEST is completed.</p>	<p>Returns to operating current display mode after 10~20 sec in any mode</p>
	<p>Returns to current display mode if the Reset button is pressed</p>	

To order an EOCR-SSD:

Selection Table

E O C R S S D - 0 5 S
① ②

①	Current Rating Range	5	0.5-6A	For 60A or higher, combine 05T Type and an external CT (Secondary 5A) for use
		30	3.0-30A	
		60	5.0-60A	
②	Operating Power Supply	S	24-240V AC/DC	
		W	380-440V AC	

Analog EOCR

EOCR-SSD

Over Current Operation Time Characteristic Curve

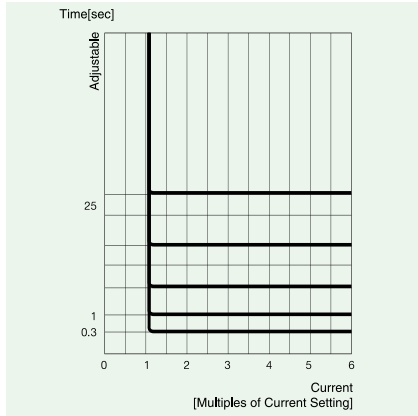
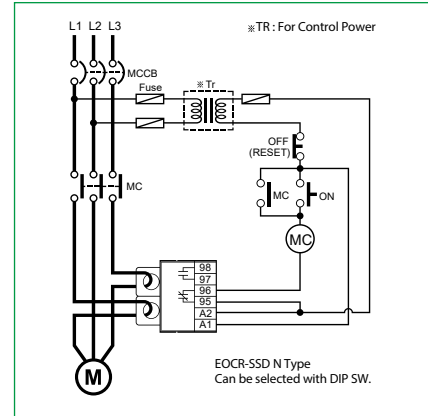
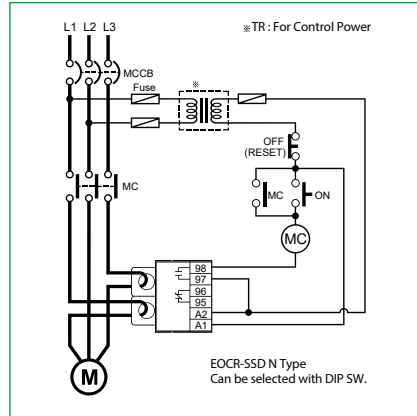
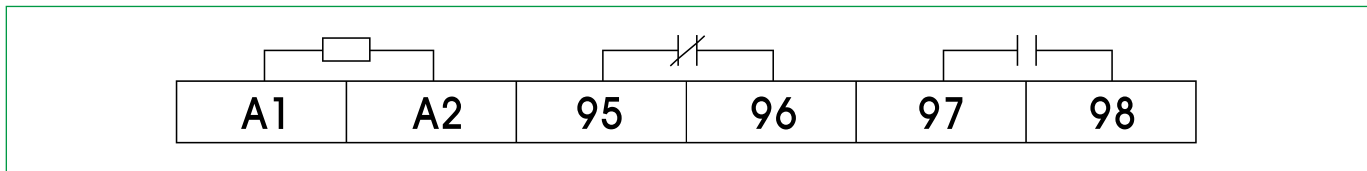

Table 1. Over Current Protection Definite Operation Characteristic Curve

Example Wiring Diagram



I/O (Input/Output) Terminal Diagram



Dimensions Diagram

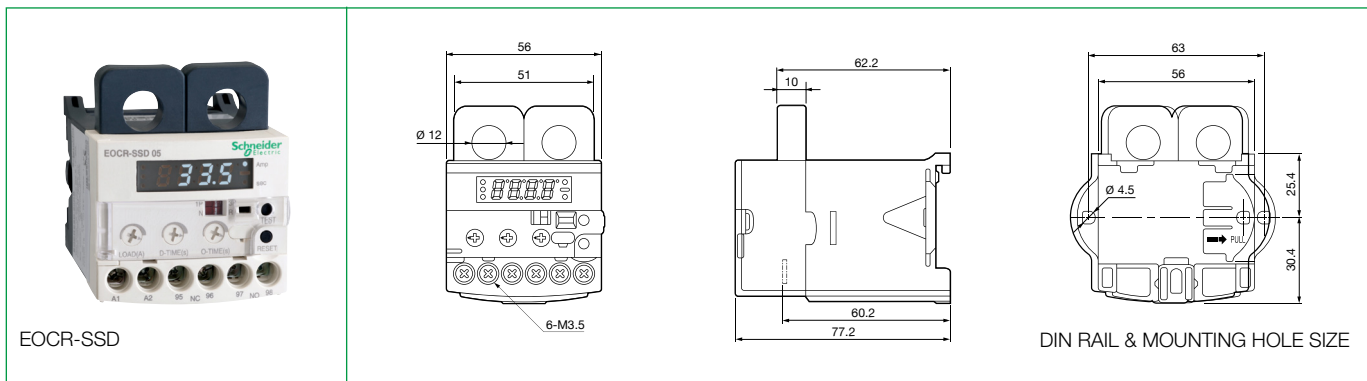

EOCR-SSD

DIN RAIL & MOUNTING HOLE SIZE

Digital EOCR



- ✓ Improved measurement precision 1%
- ✓ High frequency component filtering (Leakage, Earthing)
- ✓ High sensitivity, instantaneous operation/ leakage current protection (30mSec/30mA)
- ✓ Total Harmonic Distortion iTHD% measurement and warning alarm
- ✓ LED to indicate operation start/ stop/ trip
- ✓ Modbus SL Communication (RS485)
- ✓ Suitable for low frequency operation

Digital EOCR

A1 High frequency component filtering (Leakage, Earthing)

Leakage current measurement excluding high frequency current components when filter function is switched on

Leakage current measurement with removed impulse noise component when filter function is switched on

A2 Total Harmonic Distortion measurement & Warning Output (relay, communication)

Fundamental Wave

Harmonic Wave

Magnitude

Time Domain

Frequency Domain

60Hz

A3 Modbus Communication

PLC

EOCR-MS

nEOCR

nEOCR

nEOCR

Modbus-485 (up to 200 nodes)

A4 LED on body to indicate operation/ stop/ trip

Operations	Power (GREEN)
Start	On [Bar Graph]
Stop	On [Bar Graph]
Trip	On [Bar Graph]

Rating Specification

Functions and Properties		Rating Details
Overcurrent	Recommended current range (A)	Definite-time 0.5~80A. Above 80A use external CT Inverse time: 0.5A~32A. For 32A and above use external CT
Low current	Recommended current range (A)	0.5 ~ overcurrent setting or below, or OFF (in which case not applicable)
Operational time characteristics		Definite/Thermal Inverse
Time settings	Manoeuvre delay time	0~200 seconds
	Overcurrent/ definitetime operation time	0.2~30 seconds
	Inverse time/ characteristic curve	1~30 Class
	Undercurrent / operation time	0.5~30 seconds
	Automatic reset time	0.5 seconds~20 minutes
Power supply control	Voltage	100~ 240VAC/DC(85%~110%, Free Voltage), 24VAC/DC
	Frequency	50/60 Hz
	Power consumption	7VA
Output contact	Capacity	3A/250VAC Resistive load
	Configuration	Overcurrent: 1a1b, warning and undercurrent
Display function	7 Segment LED	3-phase current display, trip cause indicator, settings display
	Bar graph	Load factor display, 65%~100%
Communication function		Modbus/RS-485
Attachment methods		Panel attachment (i3DM), door attachment (iFDM)
Insulation resistance	Circuits and casings	DC 500V 10MQ minimum
	Circuits and casings	2kV, 50/60Hz, 1 Min
	Contact interconnections	1 kV, 50/60Hz, 1 Min
Dielectric voltage withstand	Circuit-to-circuit	1.5kV, 50/60Hz, 1 Min
Electrostatic Discharge (ESD)	IEC61000-4-2	Level 3 : Air Discharge : ±8kV, Contact Discharge : ±6kV
Radiated Disturbance	IEC61000-4-3	Level 3 : 10V/m, 80~1000MHz
Conducted Disturbance	IEC61000-4-6	Level 3 : 10V, 0.15~80MHz

Hotline: 0928.889.286 / Website: Thietbidien286.com

Digital EOCR

EFT/Burst	IEC61000-4-4	Level 3 : $\pm 2kV$, 1 Min	
Surge	IEC61000-4-5	Level 3 : 1.2x50p s, $\pm 2kV$ (0°C, 90°C, 180°C, 270°C)	
Emission	IEC61000-4-5	Class A (Conducted and Radiated)	
	Store	-40°C~+85°C	
	Operation	-20°C~+60°C	
Dimensions	Humidity	30~ 85% RH (No condensation)	
	Window Type	70Wx74.5Hx83.8D	
	Bottom Hole Type	70Wx56.3Hx108.1D	
Weight		Panel attachment	Door attachment
	Window Type	265g	247g
	Bottom Hole Type	295g	280g
	PDM (based on a 3M cable)	-	125g(120g)

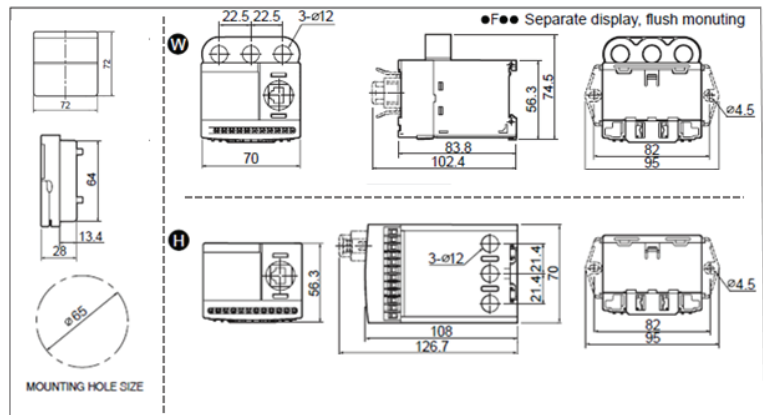
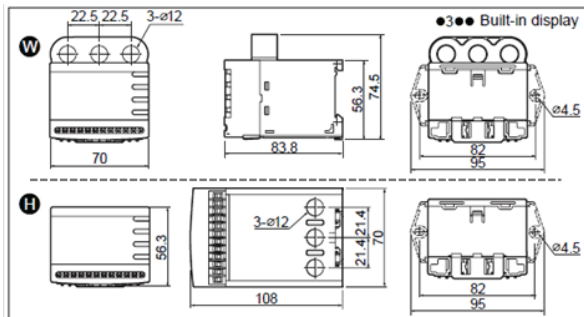

Digital EOCR

Terminal Layout

>i3DM / iFDM

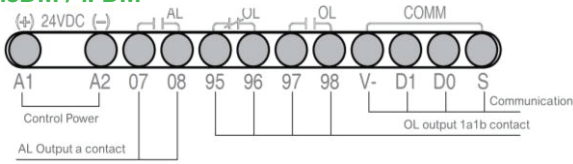

>i3MZ / iFMZ (A type)

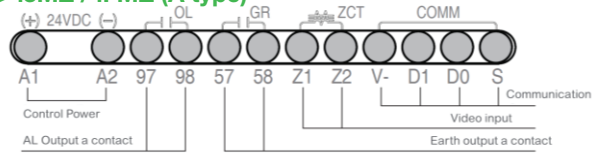

>i3M420 / iFM420

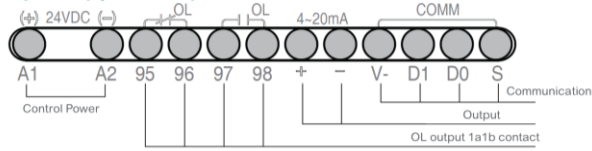

>i3MZ / iFMZ (C type)

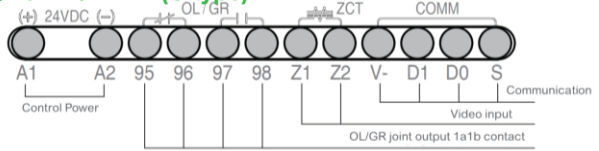

>i3MZ/iFMZ (D type)

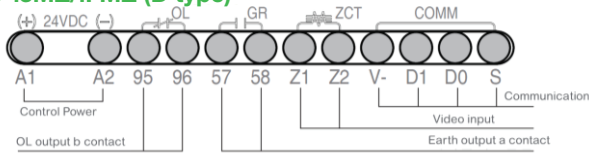

>i3BZ / iFBZ (A type)

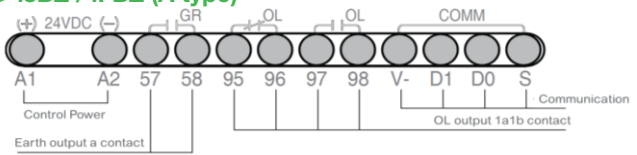

>i3BZ / iFBZ (C type)

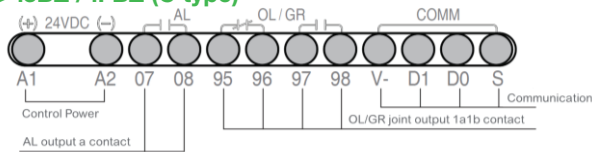

>3DM2 / FDM2

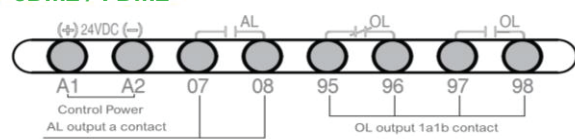

>3BZ2 / FBZ2 (A type)

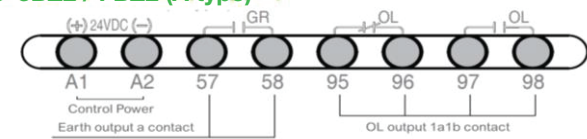

>3MZ2 / FMZ2 (A type)

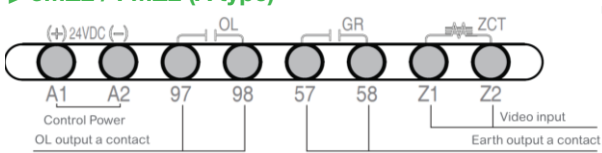

>3BZ2 / FBZ2 (C type)

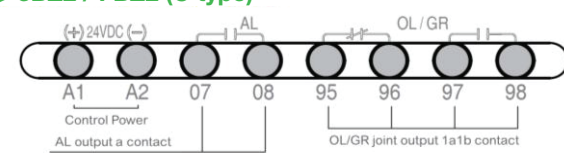

>3MZ2 / FMZ2 (C type)

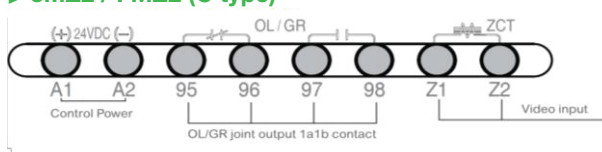

>3MZ2 / FMZ2 (D type)

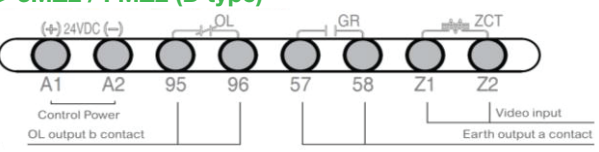

Digital EOCR

Settings sequence

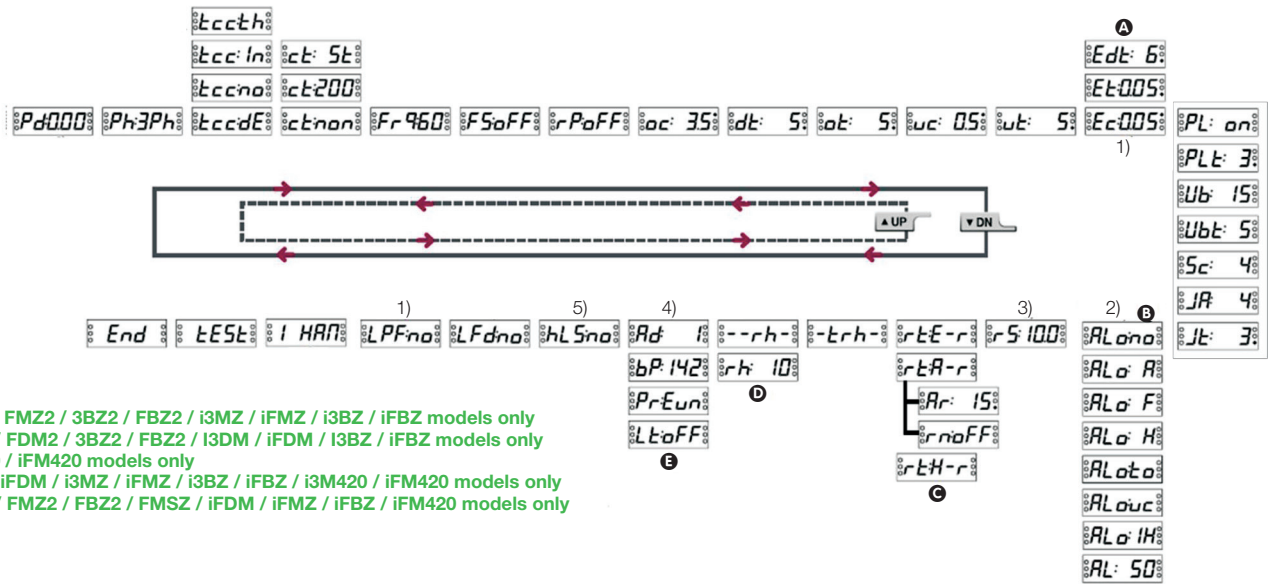

Display	Settings	Settings Range	Default	Display	Settings	Settings Range	Default
	Password setting	000 - 999	000		Manoeuvre restraint settings	2-8 > oc x Sc ≤ 40A (oc 05 selected) 2-8 > oc x Sc ≤ 240A (oc 80 selected)	4
	Single phase/ 3-phase selection	3ph, 1ph	3ph		Operational restraint settings	1,5-5 > oc x JA ≤ 40A (oc 05 selected) 1,5-5 > oc x JA ≤ 240A (oc 80 selected)	4
	Overload detection method selection	no, dE, In, th (none, definite, inverse, thermal inverse)	dE		Operating time constraint	0.2 - 10	5
	CT ratio settings	Non. 2t, 5t ct:10-3000	non		Alarm output type	no, A, F, H, to, uc, IH Temperature & humidity PDM connected no, A, F, H, to, uc, tE, hU, Pt, 4t, IH	no
	Fundamental frequency setting	50, 60	60		Alarm rate setting	50 - 100 (ALo F and H selected)	50
	Fail safe function settings	On, oFF	oFF		4-20mA output range setting	0.5 - 80	10
	Reverse phase settings	On, oFF	oFF		Error reset type (Manual, Auto, Comm reset)	H-r (Manual reset only) E-r (Electric, Manual, Comm reset) A-r (Auto, Electric, Manual, Comm reset)	E-r
	Overcurrent settings	dE: 0.5 - 80 In/th: 0.5 - 32	5		Automatic reset time	0.5 - 20n	5
	Manoeuvre delay settings	0 - 200	5		Limit number of restarts	oFF, 1 - 5	oFF
	Overcurrent operation time settings	0.2 - 30	5		Total operation time	0 - 99999	trh
	Low current settings	oFF, 0.5 - (oc-1)	oFF		Operation time display	0 - 99999	rh
	Low current operating time settings	0.5 - 30	5		Cumulative operation time Alarm output time settings	0 - 9990	oFF
	Earth current settings	oFF, 0.03 - 10	0.5		Modbus communication address	1 - 247	1
	Earth operation time	0.03 - 10	1		Communication speed(bps)	1.2, 2.4, 4.8, 9.6, 19.2, 38.4, auto	192
	Earth operation delay time	0 - 30	0		Comm parity settings even, odd, no1 stop bit= 1	non, even, odd	Eun
	Phase sequence selection	On, oFF	on		Communication interruption detection time	1 - 999	oFF
	Phase sequence operation time	0.5 - 5	2		PDM connection status check	yE, no	no
	Unbalanced settings	oFF, 10 - 50	50		Low frequency operation selection	yE, no	no
	Unbalanced operation time	1 - 10	5		Current leakage high frequency component check selection	yE, no	no

Digital EO CR

Display	Settings	Range	Default
F	Harmonics menu	1st~ 8th 5% 9th~16th : 10%	
	L1 phase current total harmonic distortion rate (no settings available)		
	L2 phase current total harmonic distortion rate (no settings available)		
	L3 phase current total harmonic distortion rate (no settings available)		
	L1 phase fundamental wave current (no settings available)		
	L2 phase fundamental wave current (no settings available)		
	L3 phase fundamental wave current (no settings available)		
F	3-phase current maximum THD alarm level settings	20 - 100	20
	3-phase current maximum THD alarm operation time, no operation while manoeuvring	1 - 30	5
	Self-test mode (not applicable during operation)		
	Self-test completion Test is Not applicable under normal operation		

Hidden Menu

Press ESC and SET buttons together and hold for at least 3 seconds to display the Hidden Menu, which contains the following items:

Display	Settings	Settings Range
	Firmware version and reference code	Firmware version (nEOCR, PDM) and Reference Code displayed in turn
	Select D-time maximum	200, 250, 300, 350, 400, 450, 500, 600
	Select maximum CT ratio	800, 3000
	Select maximum ot	30, 50, 80,120
	Select maximum ut	30, 50, 80,120
	Select phase current correction	Ld, t, S, r
	Phase current calibration	User input value
	4-20mA output calibration menu	User input value
	Power supply protection circuit operation time settings	2 sec ~ 10sec (Enhanced Version Only)
	Select surveillance mode	yE, no
	Factory reset	yE, no

Digital EOCR

Connection Diagram

i3DM
iFDM
3DM2
FDM2

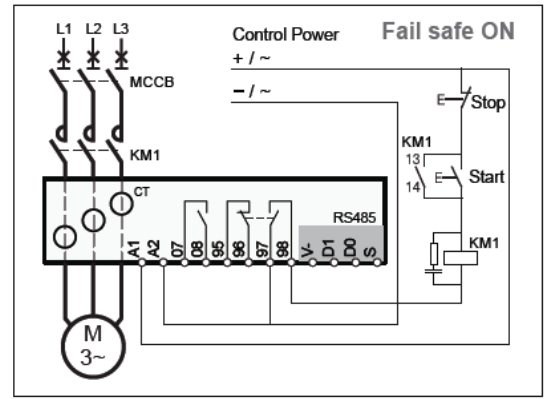
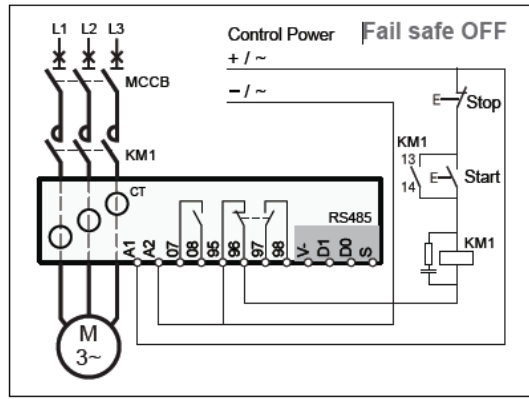
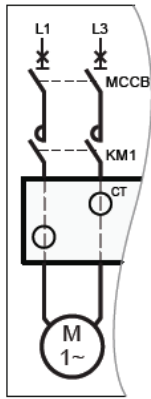

i3MZ
iFMZ
3MZ2
FMZ2

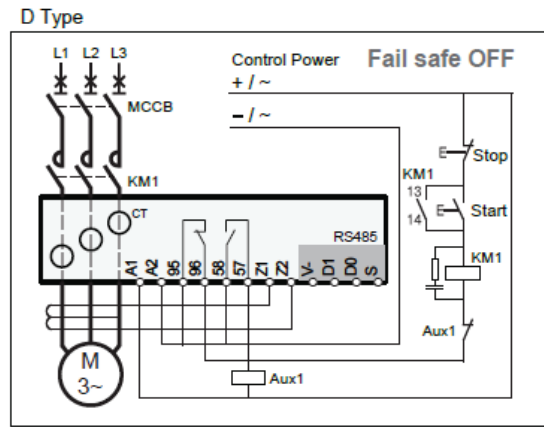
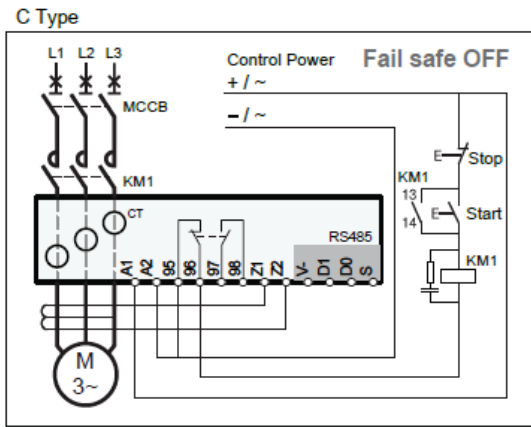
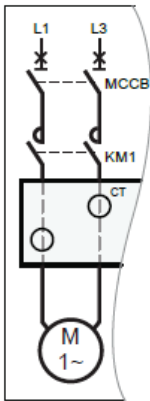
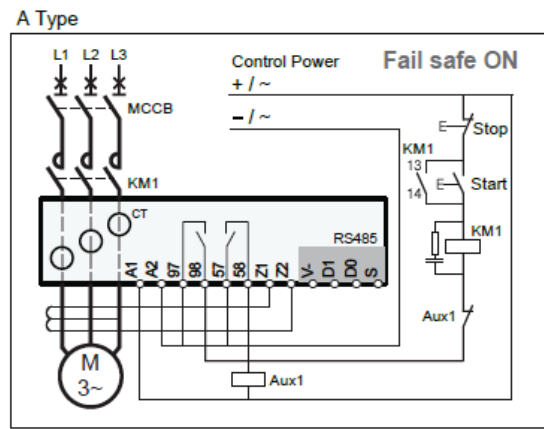
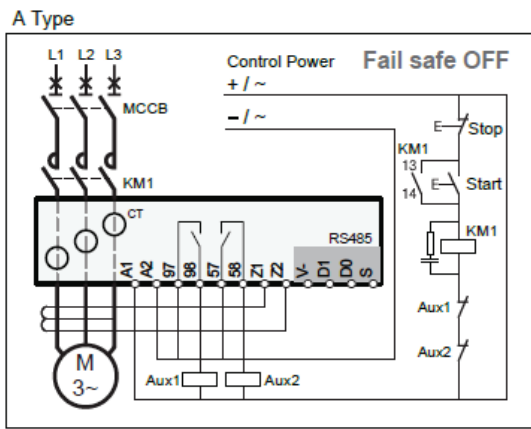
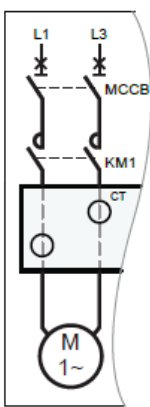

i3M420
iFM420

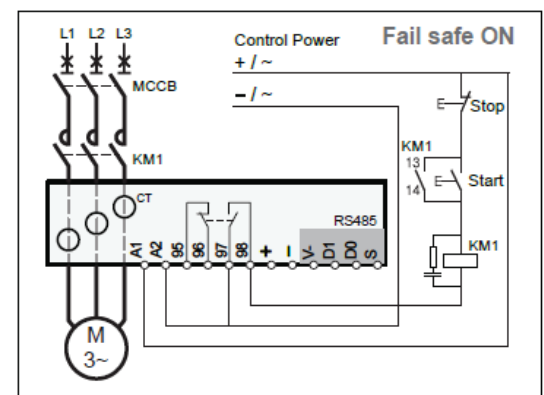
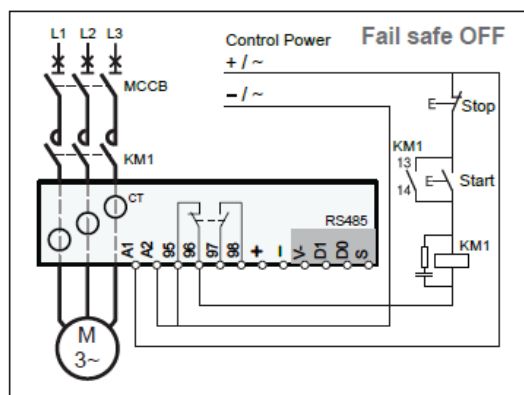
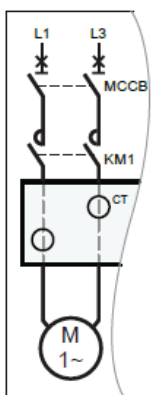

Hotline: 0928.889.286 / Website: Thietbidien286.com

Digital EOCR

Connection Diagram

i3BZ
iFBZ
3BZ2
FBZ2

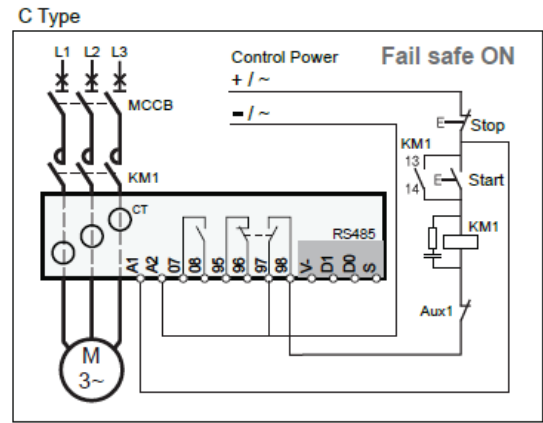
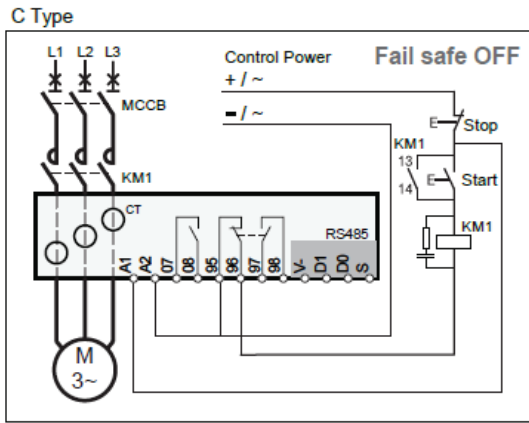
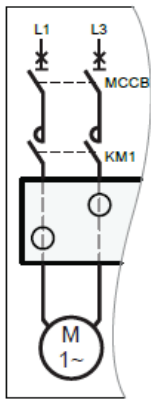
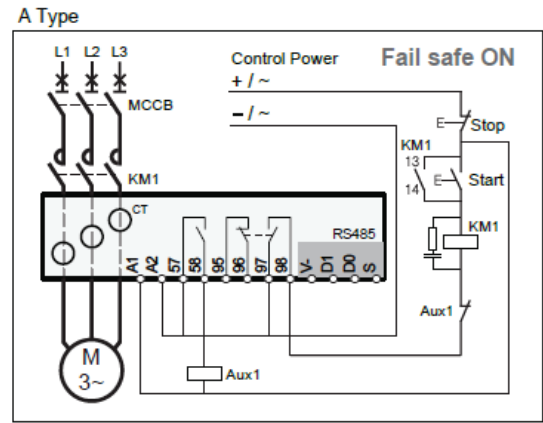
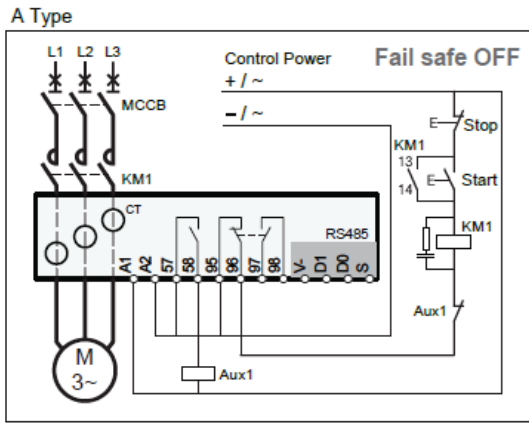
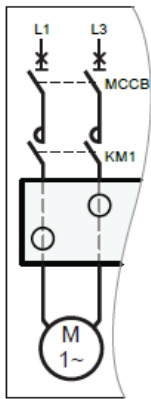

Digital EOCR

How to Order

Digital EOCR selection guide

3 **D** **M** **2** - **W** **R** **D** **U** **W** **Z**

① ② ③ ④ ⑤ ⑥

①	Digital Electronic Over-current Relay	3DM2/FDM2	Without Ground Fault Protection	
		3MZ2/FMZ2	With Ground Fault Protection with External ZCT	
		3BZ2/FBZ2	With Ground Fault Protection inbuilt ZCT	
Built-in display		3●●2	Flush mounting	display F●●2
No	Item	Type	Current Range	
②	Standard	WR	0.5...80A	
③	Relay Output	D	b (95-96), a(97-98) a(07-08)	3DM2 / FDM2
		A	a(97-98): OL, a(57-58): GF	3MZ2 / FMZ2 / 3BZ2 / FBZ2
		C	b(95-96), a(97-98): OL/GF	
		D	D(95-96): OL, a(57-58): GF*	
④	Control Power	B	AC/DC 24V	
		U	AC/DC 100~240V	
⑤	Wiring Method	W	Window-hole type*	
		H	Bottom-hole type	
⑥	Version	Z	New Version	

*Not Possible with 3BZ2/FBZ2

Communicable EOCR selection Table

①	Digital Electronic Over-current Relay	i3DM/iFDM	Without Ground Fault Protection	
		i3MZ/iFMZ	With Ground Fault Protection with External ZCT	
		i3BZ/iFBZ	With Ground Fault Protection inbuilt ZCT	
		i3M420/iFM420	With Ground Fault Protection, With 4-20 mA output	
Built-in display		i3●●	Flush mounting	display iF●●
No	Item	Type	Current Range	
②	Standard	WR	0.5...80A	
③	Relay Output	D	b (95-96), a(97-98)V a(07-08)	i3DM / iFDM / i3M420 / iFM420
		A	a(97-98): OL, a(57-58): GF	i3MZ / iFMZ / i3BZ / iFBZ
		C	b(95-96), a(97-98): OL/GF	
		D	D(95-96): OL, a(57-58): GF*	
④	Control Power	B	AC/DC 24V	
		U	AC/DC 100~240V	
⑤	Wiring Method	W	Window-hole type*	
		H	Bottom-hole type	
⑥	Version	Z	New Version	

*Not Possible with i3BZ/iFBZ

Digital EOCR

Accessories

Current Transformer

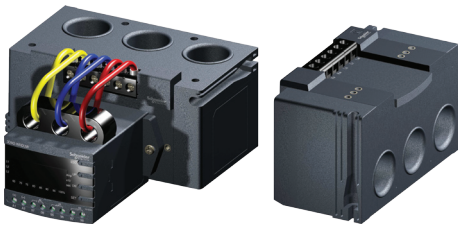

Selection Guide

Current Transformer			
3CT - H1 - 100 - C			
Reference		Description	
3CT-	① CT ratio	H1-100-C	Square 3CT 100:5
		HH-150-C	Square 3CT 150:5
		H2-200-C	Square 3CT 200:5
		H3-300-C	Square 3CT 300:5
		H4-400-C	Square 3CT 400:5

Dimensions

Type		Dimensions (mm)			
		W	D	H	Hole size (∅)
3CT	New	154.5	75	85	28.5

Specifications

Model Name	Hole Diameter	
Current Transformer Ratio	100	100 : 5A
	150	150 : 5A
	200	200 : 5A
	300	300 : 5A
	400	400 : 5A
Rating	200mA	
Burden	1.25VA	
Insulation Voltage	AC600V	
Insulation Withstanding Voltage	2kV	
Insulation Resistance	10MΩ (DC500V Megger)	
Attachment	Panel	

*Burden is based on the Metering Class.

ZCT - Zero Phase Current Transformer



Selection Guide

ZCT - Ground Fault Protection	
Reference	Description
ZCT-035Q	ZCT EP 35 MM
ZCT-080Q	ZCT EP 80 MM
ZCT-1200Q	ZCT EP 120 MM

Dimensions

Type		Dimensions (mm)		
		H	D	Hole size (∅)
ZCT-35	New	95	39	35
ZCT-80	New	143	39	80
ZCT-120	New	189	39	120

Specifications

Model Name	Hole Diameter	
ZCT	35	35mm
	80	80mm
	120	120mm
Zero Phase Primary Current	200mA	
Zero Phase Secondary Current	1.5mA	
Error Tolerance	±5%]	
Burden	10VA	
Rated Voltage	AC600V	
Insulation Withstanding Voltage	2kV	
Insulation Resistance	10MΩ (DC500V Megger)	
Attachment	Panel	

Display Cable for F**2 / iF**



Reference	Description
CABLE-RJ45-001Q	CABLE 1M
CABLE-RJ45-003Q	CABLE 3M